

Headquarters

Otto Männer GmbH
Unter Gereuth 9-11
79353 Bahlingen
Germany
Phone +49 (0) 7663 609-0
Fax +49 (0) 7663 609-299
info@maenner-group.com

Europe

Otto Männer GmbH
Unter Gereuth 9-11
79353 Bahlingen
Germany
Phone +49 (0) 7663 609-0
Fax +49 (0) 7663 609-299
sales@maenner-group.com

Switzerland
Otto Männer
Präzisionsformenbau AG
Feldstrasse 11
9494 Au/SG
Switzerland
Phone +41 (0) 71 747 99 52
Fax +41 (0) 71 747 99 66
sales@maenner-group.com

Denmark/Sweden
H. Saxe Hansen A/S
Walgerholm 17
3500 Værløse
Denmark
Phone +45 (44) 977022
Fax +45 (44) 975055
info@hsh.as

North America

Manner USA, Inc.
1105 Progress Industrial Blvd.
Lawrenceville, GA 30043
USA
Phone +1 770 449 1820
Fax +1 770 449 1821
sales-usa@maenner-group.com

Asia

Hong Kong
Manner Hong Kong Ltd.
Suite No. 8B, 11/F, Tower 1
China Hong Kong City, 33 Canton Road
Tsim Sha Tsui, Kowloon, Hong Kong
Phone +852 2345 12 81 / 2345 12 87
Fax +852 2345 12 91
sales-hongkong@maenner-group.com

Shanghai
männer Solutions for Plastics (Shanghai)
with Asia Solution Corporation
Suite 2806 Hyundai Plaza,
369 Xian Xia Rd.
Changning District Shanghai,
China, PC: 200336
Phone +86 21 5217 7225
Fax +86 21 5217 9434
sales-shanghai@maenner-group.com

Japan
Männer Japan Co., Ltd.
30-8, Sumiyoshi-cho, Mito, Ibaraki
310-0844 Japan
Phone +81 29 212 33 41
Fax +81 29 212 33 19
sales-japan@maenner-group.com

08/15 Technical specifications subject to change. Actual colors may differ.

High Precision Molds – System Solutions

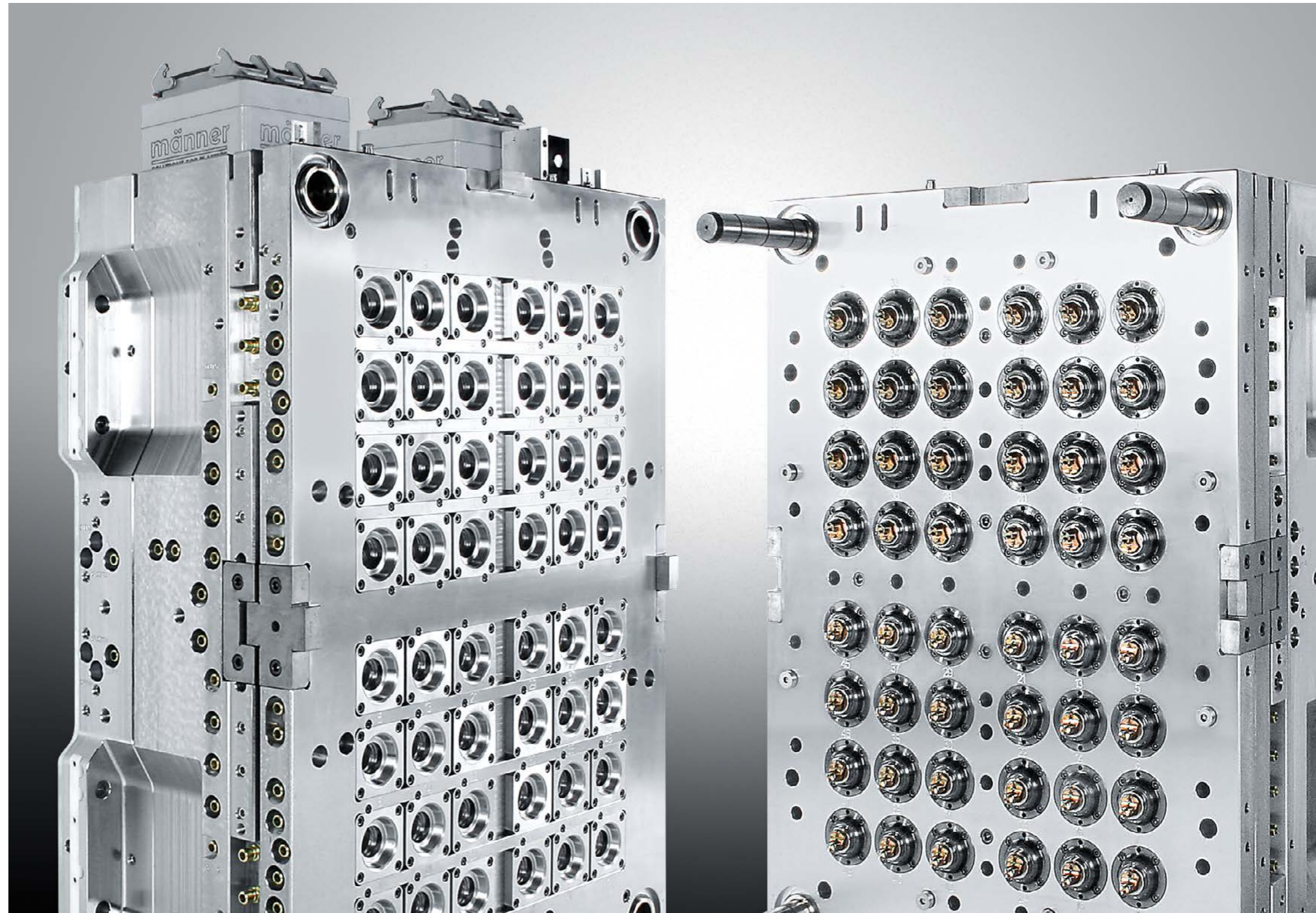



MEDICAL

- Precision and part-to-part consistency
- Hygienic surface quality



PERSONAL CARE

- Surfaces with high-quality look and feel
- Resilient functional areas



PACKAGING

- Thin-wall products
- Very short cycle times

High Precision Molds and System Solutions for Plastic Injection Molding

It is our responsibility to ensure that the product ideas of our customers are brought to fruition reliably and profitably. Our engineering experts assist you every step of the way – from the conception stage to the delivery of comprehensive product solutions.

männer high-precision molds are extremely durable, high-performance molds specifically designed for large-volume production of precision injection-molded parts. We develop our high-precision molds with an eye on part-to-part consistency and reproducibility, which are essential to automated downstream processing of the injection-molded parts.



Project management

A project manager with valuable experience in documentation and validation processes provides you with full project support – from inception to start-up of your production molds.

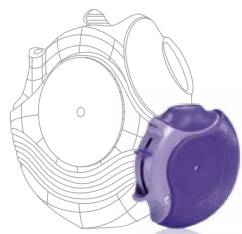

Engineering

Relying on our extensive experience in injection molding technology and comprehensive process know-how, we deliver targeted expert knowledge in all stages, from product development to smooth and efficient production.

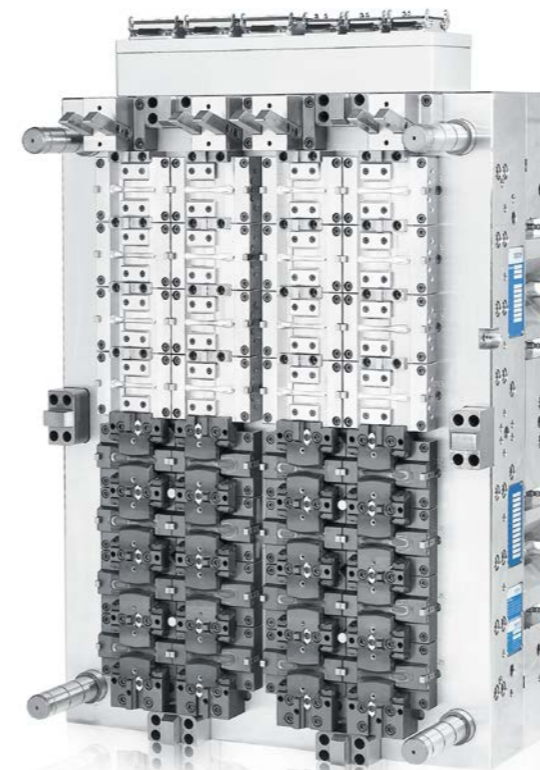
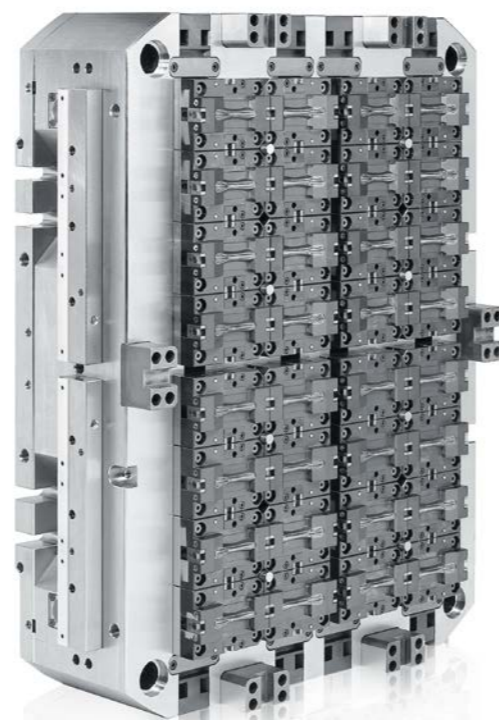

Injection molding solutions

In addition to injection molds, we deliver a range of components to maximize production reliability:

- männer's valve gate hot runner technology
- Hot runner control units
- Injection molding units
- Micro injection molding systems



Resources for comprehensive projects

When it comes to the production of plastic products composed of numerous individual parts, we are your ideal single-source provider of full-range pilot and production molds together with matching hot runner systems.

Comprehensive Complex Projects
Demanding Components
Extensive Expertise



Pharma Devices and Medical Disposables

Products for medical and pharmaceutical applications are subject to strict quality requirements. Precision, cleanliness, and reliability are paramount. This applies not only to devices such as inhalers or insulin pens, but also to medical disposables. The proper functioning of every product is essential to guaranteeing an optimum level of patient safety. To help you to create perfectly functioning components, we deliver cleanroom-compatible injection molds for the production of high-precision individual components with maximum part-to-part consistency.

Regardless of where your production is located, you can rely on uniform mold specifications and high-level reproducibility. All männer molds are equipped with männer's own valve gate hot runner systems, ensuring clean and hygienic surfaces.



Syringe barrel made of COC carrier

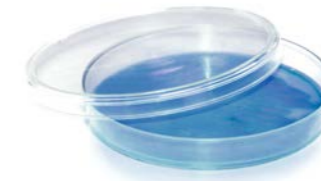

Petri dish



Sample carrier



Inhaler consisting of 14 individual parts



Insulin pen consisting of 12 individual parts

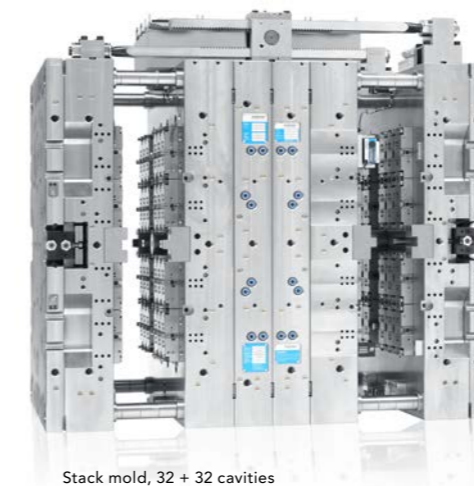

Stack mold, 32 + 32 cavities

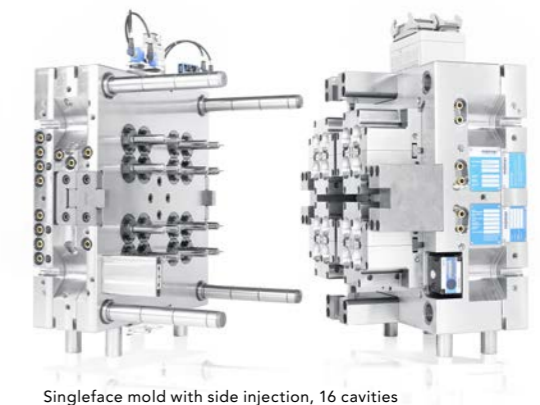

Singleface mold with side injection, 16 cavities

Impeccable Surfaces Resilient Functional Areas



Personal Care/Health Care

Consumer trends greatly influence products for personal care and cosmetics. The buyer's interest is focused on high-quality appearance. When it comes to surface quality and injection points, plastic products must be capable of meeting the most demanding requirements for look and feel. Simultaneously, functional areas of the product are put to the test. For instance, flip caps not only need to be easy to open, but must also form a correct seal when closed.

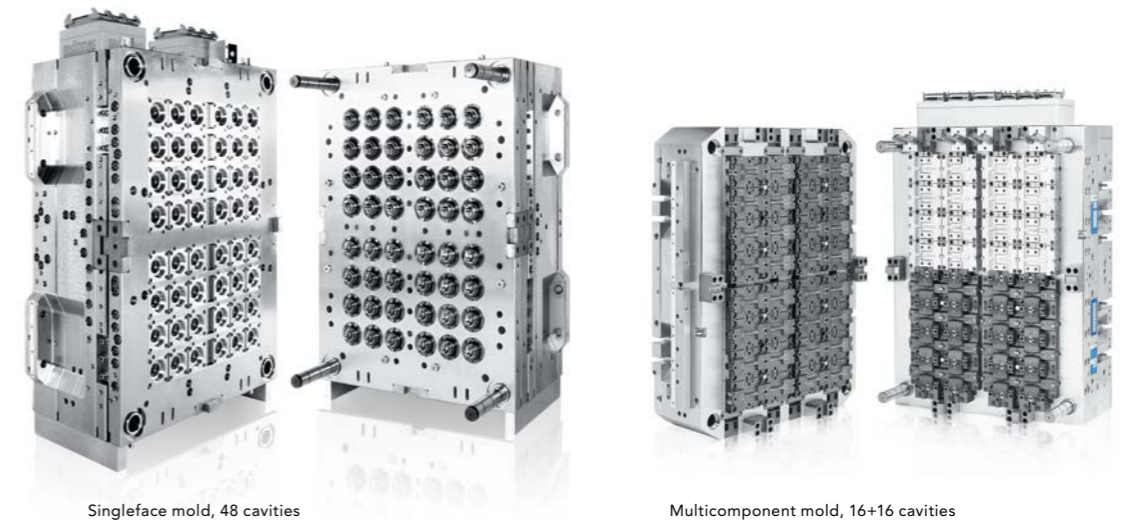

Thin-Wall Technology High-Speed Molds

IML – In-Mold-Labeling.

The IML process involves inserting the label into the injection mold and injecting plastic from behind, making it possible to reduce wall thickness. Temperature control is the key to achieving impeccable results. männer valve gate hot runner systems enable virtually constant melt temperatures for the entire distance of flow. Nozzles are designed to maximize flow rates. The size of the gate orifice, meanwhile, depends on the application involved.

Packaging

Impeccable surfaces are what set high-quality food packaging apart: smooth, hygienic, and attractive plastic with premium in-mold labeling. Thin-wall products like these are produced in extra high-speed molds with ultrashort cycle times. Injection speeds are very high, requiring a mold design stable enough to handle cores that can be quite large. The hot runner system has a crucial impact on the quality of the plastic part. Virtually constant melt temperatures and maximum flow cross sections ensure that the melt is able to transition uniformly into the cavity.



Tamper-proof cap



Container (IML)



Detergent container, lid with safety lock

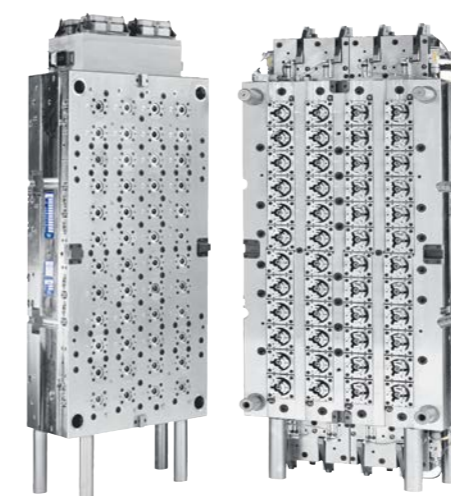

Singleface mold, 48 cavities

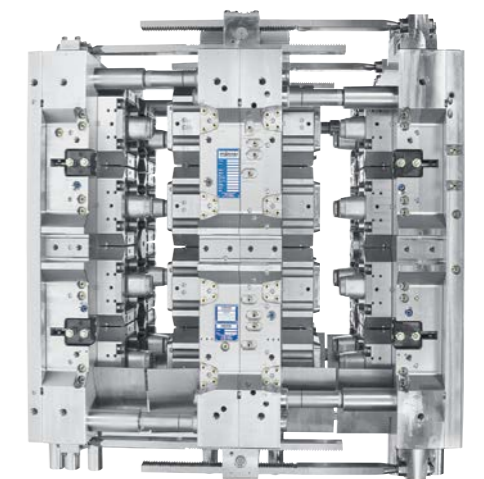

Stack mold, 2 x 8 cavities

männer High Precision Molds

männer's high-performance injection molds are specifically designed for large-volume production of high-precision thin-wall plastic parts. We develop our molds with a focus on part-to-part consistency and reproducibility, which are crucial for automated downstream processing of the injection-molded parts.

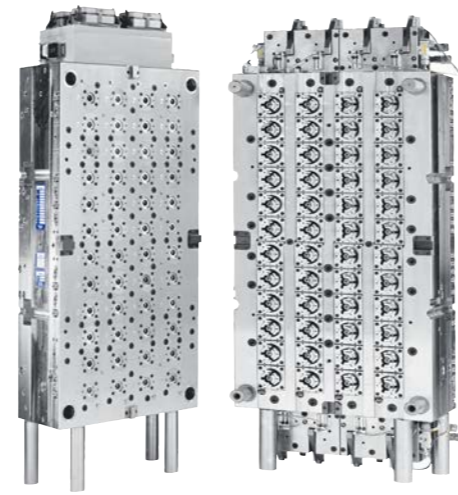

Singleface molds

Optimized mold design for superior precision, stability, and cooling

- Long life
- Maximum repetition accuracy
- Easy maintenance
- Up to 128 cavities

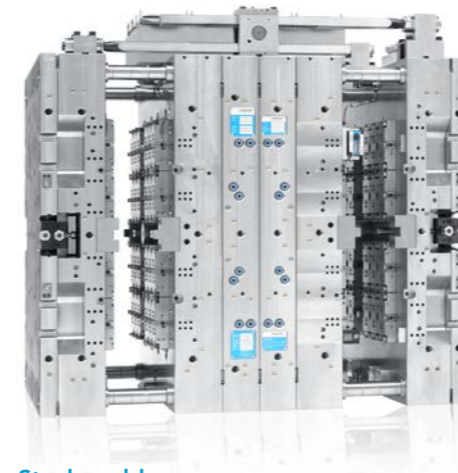

Stack molds

- For high-volume production
- Stack molds with two or four parting lines
- Two or four times the output quantity per cycle when compared to singleface molds using the same closing force
- Energy savings of up to 50%
- Reduced space requirements
- Specially developed hot runner stack technology

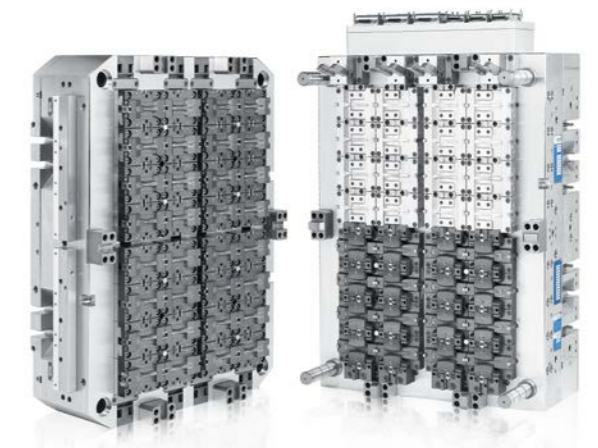

Multicomponent molds

- Economical production of parts comprised of two or more different types of plastic materials and/or colors
- High cavitation with use of a wide range of technologies such as turntable, core-pulling, and transfer methods
- Insert overmolding
- For production of up to five components



Stable mold design

- Ejector plate cut-outs milled out of solid steel
- Efficient cooling in all cavity plates
- Parallel interlocks for centering of the mold halves

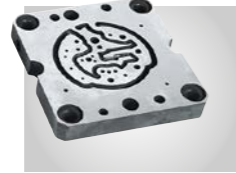

Temperature-optimized mold inserts

The cooling system design is a critical factor determining the cycle time of an injection mold.

- Balanced temperature control made possible by cooling channels that precisely follow the part geometry
- Complex geometries can be processed with the help of cutting-edge fabrication technologies such as Lasercusing®, vacuum brazing, and diffusion welding
- Use of special materials such as copper alloys

Easy-change principle

Easy maintenance thanks to „easy-change“ principle: Mold inserts can be accessed without unclamping the mold and exchanged without additional adjustment

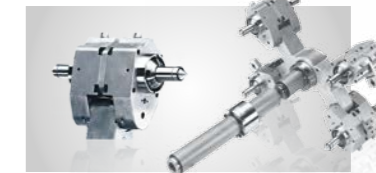

Proprietary hot runner valve gate technology with special stack technology

Hot runner technology has a crucial impact on the cost-effectiveness and part quality in injection molding. As a pioneer in hot runner technology, we focus on the development and manufacture of Cylindrical Valve Gate Systems – recognized as the best hot runner solution for achieving impeccable surface quality, part-to-part consistency, and process reliability.

All valve gate systems are custom tailored and optimized to meet the specific needs of our customers. That is why leading moldmaking companies worldwide trust in the perfect functionality and longevity of the original by männer.

We have custom-developed a valve gate system for stack molds. Benefits:

- Injection points lie on a single axis
- Split snorkel provides room for handling systems
- Minimal assembly height of middle platen
- Direct injection with männer valve gate hot runner technology

From Idea to Serial Production

We support you in every phase of the creation of your product with our engineering know-how and extensive experience. With our design, manufacturing, and project management resources, we are your one-stop source for the full range of pilot and production molds – even for extensive, complex mold projects. An experienced project manager at männer is assigned to your project right from the start.



High-speed cutting (HSC)

- 3D design
- Wire / sinker EDM
- 5-axis high-speed cutting
- männer Heat Treatment (hardening / nitriding)
- männer Test Center (injection molding machines from 75 to 500 t)
- Protomold
- männer Polishing
- Surface, profile, and jig grinding
- Lasercusing®
- männer Training Center
- ISO 9001:2008



EDM Center



Fully automatic milling center
with 5-axis milling machines

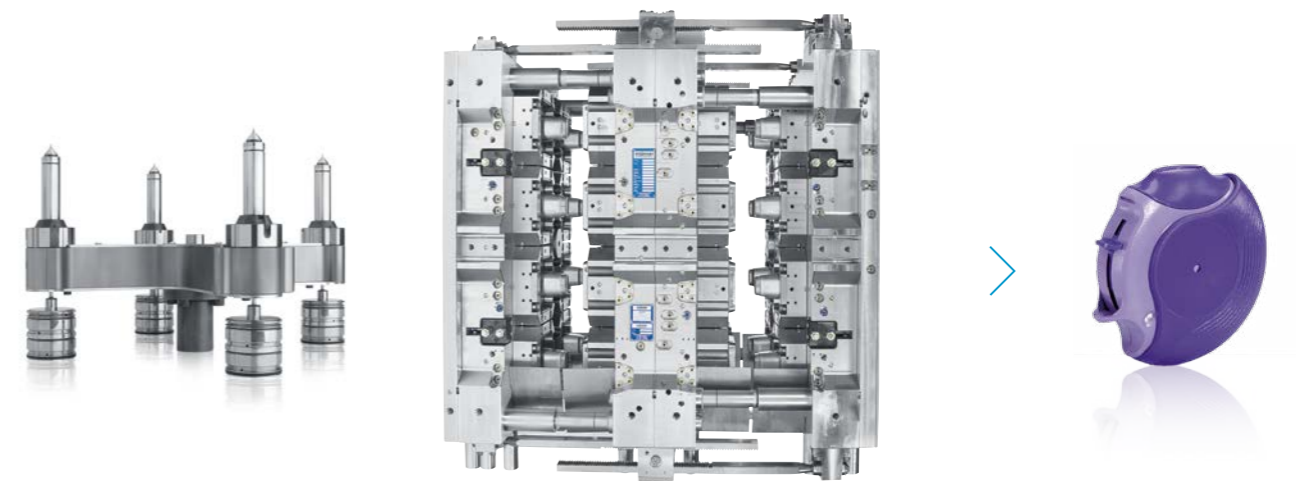

Protomold for pilot molds, repairs, and mold optimization

Working outside of production workflow, our autonomous department is able to react quickly to find urgent solutions.



Test Center with injection molding machines from 75 to 500 tons

For mold acceptance, product development, and materials testing. We offer the option of installing your own injection molding machine within a complete production environment.

männer

SOLUTIONS FOR PLASTICS

 A business of BARNES GROUP INC

High-precision molds

For large-volume production of reproducible injection-molded parts with maximum part-to-part consistency

Extremely durable and easy-to-maintain high-performance molds with optimum temperature control for short cycle times.



Valve gate hot runner systems

Tailored and reliable

Recognized as the superlative hot runner solution for impeccable surface quality, part-to-part consistency, and process reliability.



modalMIND

The black box of the injection mold

Tamper-proof recording of all process-relevant data, providing factual evidence in the event of disputes and for other uses.



Your One-Stop Source

Reliability and cost-effectiveness in production:

- Perfectly coordinated components
- Extensive engineering know-how
- Dedicated contact person for your project



duo-män

Injection molding units for multicomponent applications

Turn one component into two – high-precision dosing of even the smallest injection volumes.

HCS 2 series

Temperature controllers

Easy-to-use control technology with the latest functions such as early recognition of leaks.



micro-män

Production cells for micro injection molding

For both large-volume and small-scale production of precision miniparts and microparts. Can be custom configured for a wide range of production needs.



Plant I: High Precision Molds in Bahlingen

Plant II: Hot Runner Systems in Bahlingen

Plant III: in Bahlingen

Plant IV: High Precision Molds in Au, Switzerland

Plant V: Manner USA, Inc.

männer develops high-tech solutions for injection molding applications. We offer high-performance molds, tailored valve gate hot runner technology, and innovative micropart manufacturing systems for the production of plastic parts capable of meeting the most demanding requirements for precision and surface quality.

Founded in 1965, männer is among the industry's leading suppliers, with over 450 employees and production, sales, and service locations in Europe, the USA, and Asia.

Since 2013 männer is part of Barnes Group Inc. For further information please visit www.BGInc.com

Headquarters in Bahlingen

