

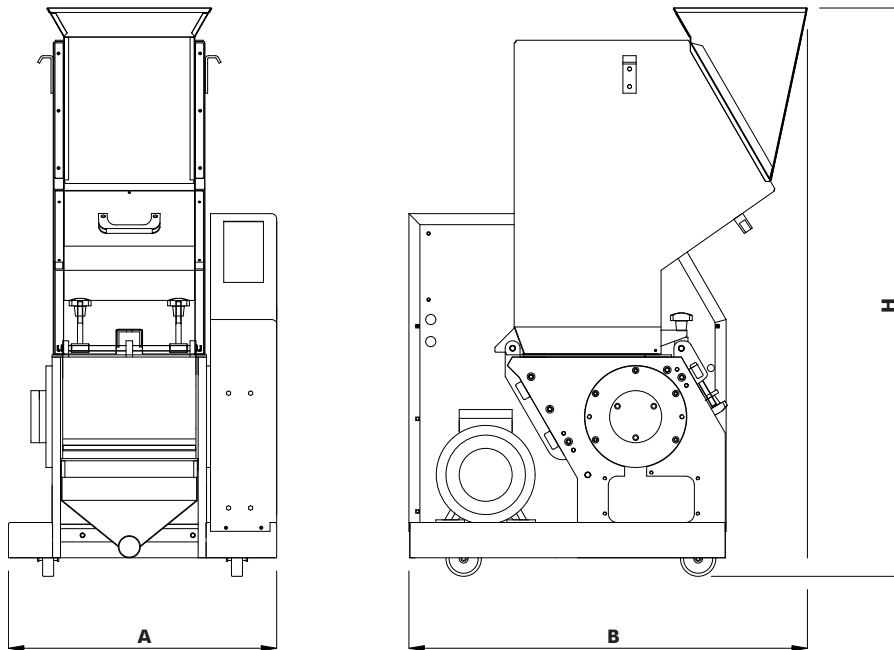

Listening

GRANULATORI GRANULATORS

GR



Applicazioni - Applications

Modello Model	Valvola proporz. Ratio Valve Mod.	Coclea inclinata Inclined screw Mod.	Ventilatore ciclone Cyclone fan Mod.	Cassetto maggiorato Enlarged drawer Mod.	Diametro fori griglia ¹ Screen hole diameter [mm]					
					3	4	5	6	8	10
GR 20/20	VP 20/20	CI 20/20	VC 20/20	CM 20/20		○	○	●	○	
GR 20/30	VP 20/30	CI 20/30	VC 20/30	CM 20/30		○	○	●	○	
GR 30/35	VP 30/35	CI 30/35	VC 30/35	CM 30/35			○	○	●	○

1 = Griglia a parte / Screen is separately sold

○ = Consigliati / Recommended.

● = Standard

Dimensioni - Dimensions

Modello Model	Valvola proporz. Ratio Valve	Coclea inclinata Inclined screw	Ventilatore ciclone Cyclone fan	Cassetto maggiorato Enlarged drawer	A	B	H	Peso Weight
					mm	mm	mm	kg
GR 20/20	•	•	•	•	508	903	1288	260
GR 20/30	•	•	•	•	608	903	1288	310
GR 30/35	•	•	•	•	770	1120	1530	680