



High Performance made  
to measure  
Machines of the ELION Series

*Engineering Excellence*



## Application Areas of the ELION Series



Closures



Packaging



Medical components



Technical components

**Securely closed:**  
**Closures and closure systems for an extremely wide range of application areas**

Thanks to its performance and energy efficiency, the ELION is excellently suited for the highly productive manufacture of beverage closures. Its high precision means that it's also ideal for use in complex closure systems such as flip-top and push-pull designs.

**Well-packaged:**  
**Thin-walled packaging parts**

To save raw materials and transport weight, ever-thinner wall thicknesses are used in the packaging industry, resulting in a demand for wall thickness to flow path ratios that are extreme in some cases. Due to the well-conceived performance concept, machines from the ELION series are excellently suited for the production of demanding thin-walled parts.

**Vitally important:**  
**Consumable materials and equipment components for medical technology**

Molded parts and components for use in medical technology are often produced in clean rooms. In terms of design and specifications, this enables especially demanding requirements for the entire production infrastructure to be met. The ELION already offers a broad range of features at a basic equipment level that provide considerable support for use in clean rooms.

**Zero tolerance:**  
**Technical precision parts**

Precision parts, for example such as those used in the electronics and automotive sectors, place the most demanding requirements on manufacturing processes and their reproducibility. Thanks to its solid design, intelligent control technology and many smart detailed solutions, the ELION is excellently suited for this task. In addition, it is also designed for low-wear, low-maintenance operation, and therefore has a long service life.

## Machines of the ELION Series Low Energy High Performance

Fast, precise, reliable, user-friendly and efficient in operation. These are the most important characteristics of our ELION series. The theme of their development is "Low Energy, High Performance". That means: top performance and optimized energy efficiency. Thanks to a consistent modular design and a large number of additional equipment options, ELION can be optimally adapted to meet the needs of various application areas.

### The benefits of the ELION series at a glance

- Minimal piece costs
- Best possible productivity
- Smallest CO<sub>2</sub> footprint
- Low noise level
- Highest performance

# Fully electric, entirely innovative A Fascinating Tour of the ELION with fully electric drive system

**Clean mold mounting area**  
Clamping unit with central  
5-point toggle lever, closed-loop  
lubrication system and precise  
linear guides



**Modern control technology**  
Easy handling thanks to  
process-oriented interface

**High-precision injection unit**  
Injection unit with high-precision  
dual rack and pinion drive and  
dynamic servo motors



**Well-conceived media concept**  
Flexible solutions for the supply  
of mold and peripheral devices



# Top Performance, Optimal Efficiency A Fascinating Tour of the ELION with Hybrid Drive Concept

- Your benefits:**
- The ideal drive technology for each movement axis
  - Top performance
  - Optimal energy efficiency
  - Low noise level
  - Low emissions

**Flexible operating unit**  
The innovative aXos control offers freely programmable processes and maximum flexibility. As a result, the user experiences a previously unknown level of user friendliness.

**High-performance injection unit**  
Hybrid driven injection unit with extremely high injection performance and extremely high control accuracy



**Dynamic clamping and opening movements**  
Central 5-point toggle lever according to the unique ELION principle with extended clamping force range

**Hybrid drive technology**  
Innovative Eco Powerunit drive unit with adaptive drive control and optimal energy efficiency

ELION

## Unique Design Principle Innovative Detailed Solutions

Robust and durable – the basic principle of the ELION



Machines from the ELION series meet the most demanding requirements with regard to process control as well as quality of molded parts and production performance and are primarily used to manufacture particularly demanding plastic molded parts. Thanks to its unique design principle and innovative detailed solutions, the ELION sets the market standard with regard to performance and energy efficiency.

### Clamping unit with unique ELION toggle lever

The innovative, unique clamping principle of the ELION enables extremely fast and nevertheless harmonious mold movement. In addition, this operating principle has an extremely high efficiency level and therefore contributes to optimal energy efficiency.

### Top precision and reproducibility

When it comes to our all-electric injection units, we rely on a highly dynamic, long-life dual rack and pinion drive. Compared to spindle solutions common on the market, this variant offers considerably higher performance and top precision and reproducibility.

### Extreme injection performance and high control accuracy

The hybrid variant of the ELION is equipped with a high-performance injection unit. Injection speeds of up to 2,000 mm/s are available for thin-wall applications. As a result, Netstal is the market's number one manufacturer.

#### Your benefits:

- Top performance
- Excellent energy efficiency
- Precision and reproducibility
- Long service life
- Reliability



All-electric precision injection unit



Hybrid high-performance injection unit

## Clamping Unit and Injection Unit Solutions of the ELION Series

The ELION series follows a consistent modular system principle: Clamping unit, plasticizing unit, injection unit and drive can be combined to meet your needs.

As a result, you receive a customized system that is of optimal size and design. For lower clamping forces, we utilize an all-electric drive concept. For medium and high clamping forces, the electrical clamping unit of the ELION is equipped with a highly efficient hybrid injection unit. Complete modularity is reached

when all logical combinations are possible via the existing clamping forces and injection unit sizes of a series. New injection units are already being developed. All-electric models with greater clamping forces will also be available in the near future.

### ELION is the series with a modular assembly system for universal use

Hybrid injection units	1000			2000			2900		4200	
Screw Ø	45	50	55	55	62	70	70	80	80	90

Electrical clamping units	1000			2000			2900		4200	
2200 kN										
2800 kN										
3200 kN										
4200 kN										

Electrical injection units	60				130				270				530				840			
Screw Ø	16	18	20	25	20	25	28	32	28	32	35	40	35	40	45	50	45	50	55	62

Electrical clamping units	60				130				270				530				840			
500 kN																				
800 kN																				
1200 kN																				
1750 kN																				

#### Your benefits:

- Optimal design of machine components
- Maximum flexibility
- Future security
- Optimal ease of maintenance

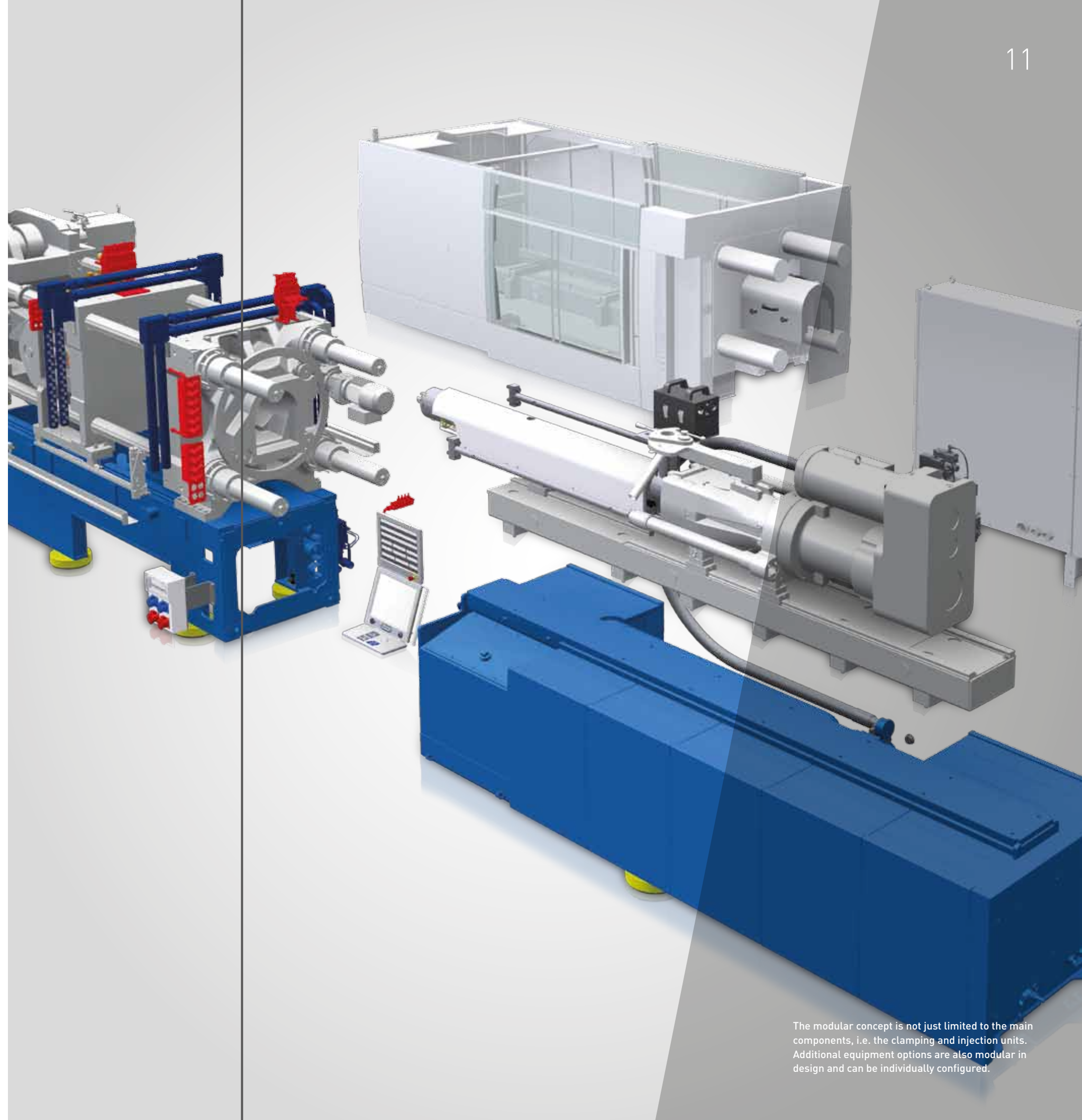

The modular concept is not just limited to the main components, i.e. the clamping and injection units. Additional equipment options are also modular in design and can be individually configured.

Innovative solutions, optimal energy efficiency  
The high efficiency of the clamping unit can be attributed in large part to the low-friction movements of the moving mold plate.

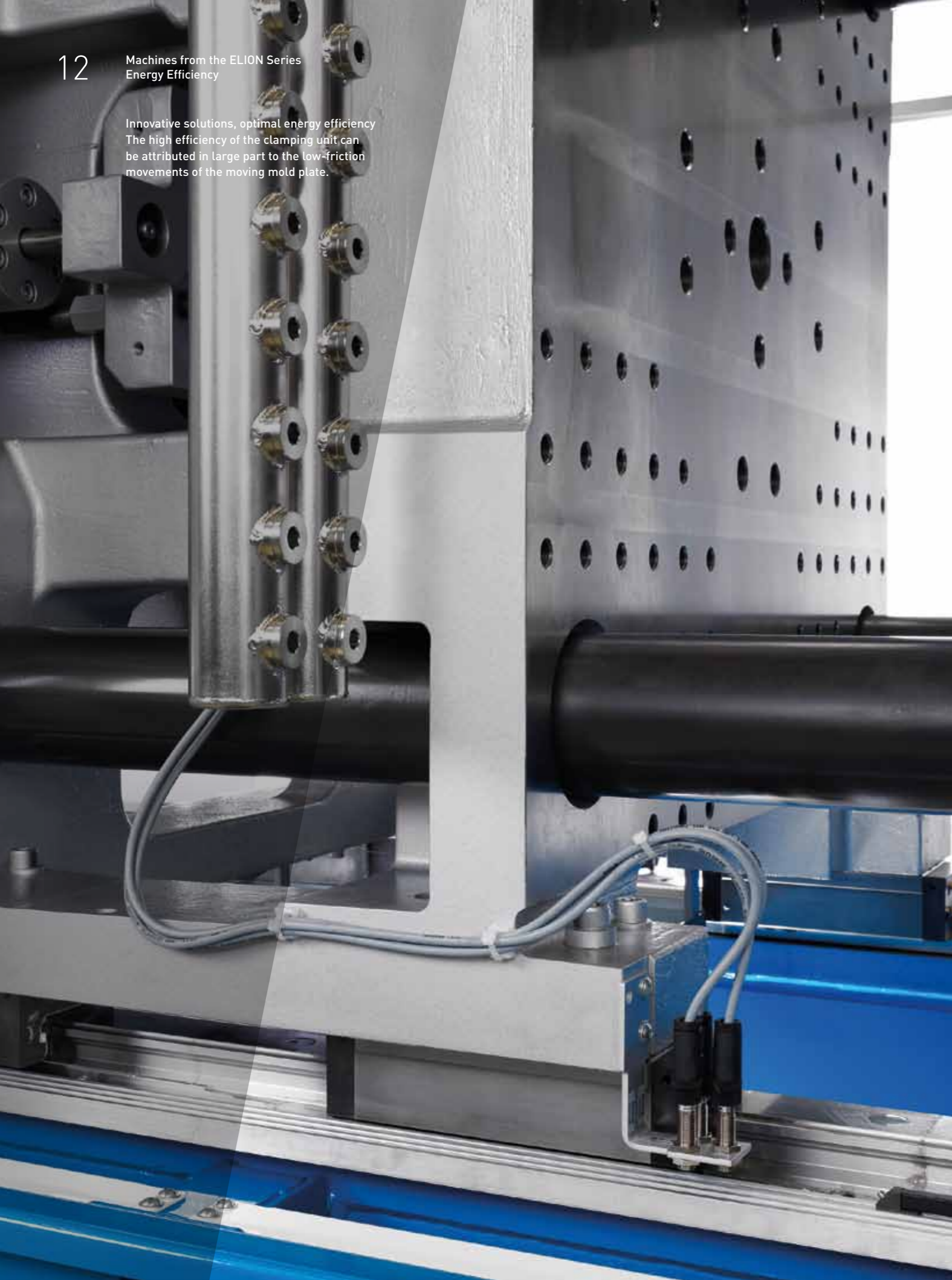

## Low Energy, High Performance Efficient Drive Concept

The actual operation of the machine is responsible for the largest proportion of its energy consumption by far. Thanks to the innovative concepts of the ELION and intelligent drive technology, enormous energy savings can be achieved with hybrid or all-electric injection molding machines. This is largely thanks to the following key characteristics:

- Complete recovery of kinetic energy
- Adaptive drive control
- Interconnected power converters –  
Optional operating point at  
maximum efficiency

Based on its low consumption values, the ELION is a machine that stands for maximum efficiency. When coupled with the Eco Powerunit, it delivers energy savings of up to 50 percent compared to conventional hydraulic machines. If an all-electric machine is used, efficiency is increased again by around a further 10 percent.

### Energy efficiency stands for sustainability

It is anticipated that energy costs will rise further in the future to become the second most important cost factor after material costs. Netstal is committed to developing innovative systems and solutions that ensure optimal energy efficiency at maximum productivity in line with our motto: "Low Energy, High Performance".

Energy consumption comparison

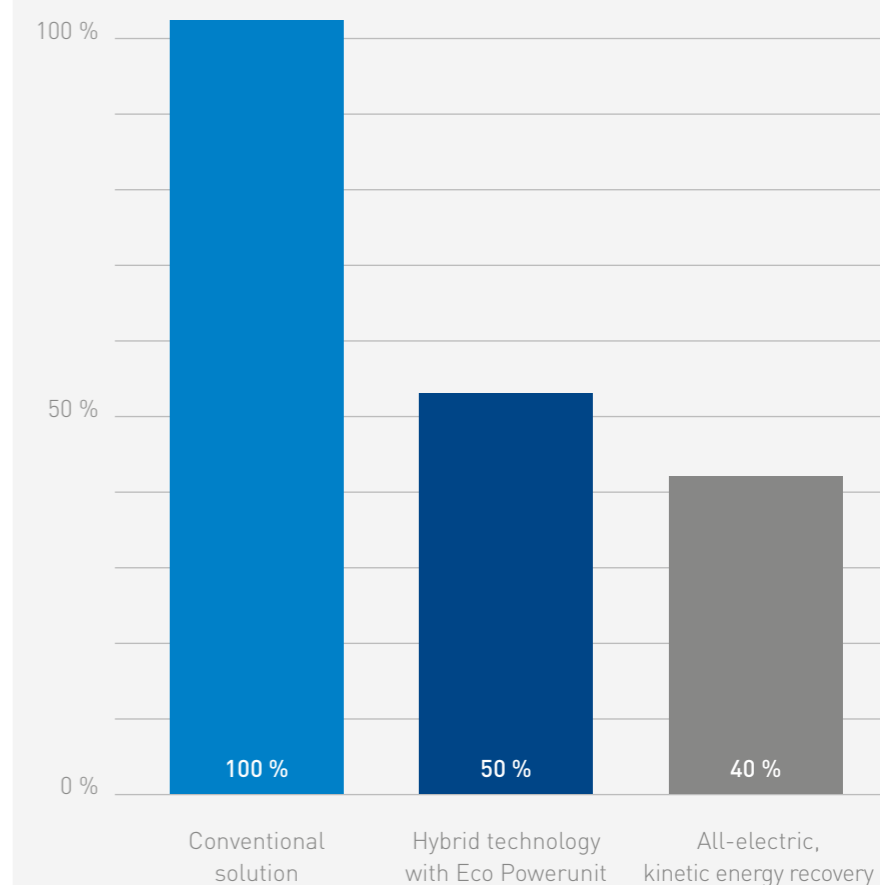

## Simply Clever Maximum Flexibility of Media

### Pneumatic valves

The pneumatic valves are optimally arranged to ensure the fastest reaction times.

### Hydraulic controls

The connections for hydraulic auxiliary mold control can be installed on the operating or the non-operating side of the machine as preferred.

### Cooling water distributor

Depending on the mold, cooling water distributors are available for any position on the mold plates. The distributors are protected against corrosion and an optimal flow rate is guaranteed thanks to the use of ball valves.

### Socket outlets

Optional socket outlet with integrated circuit breakers can be installed in various positions on the machine to connect peripheral devices.

### Clear connection layout

All connections for machine and tool cooling as well as the pneumatic system are located on the front and are therefore easy to access.

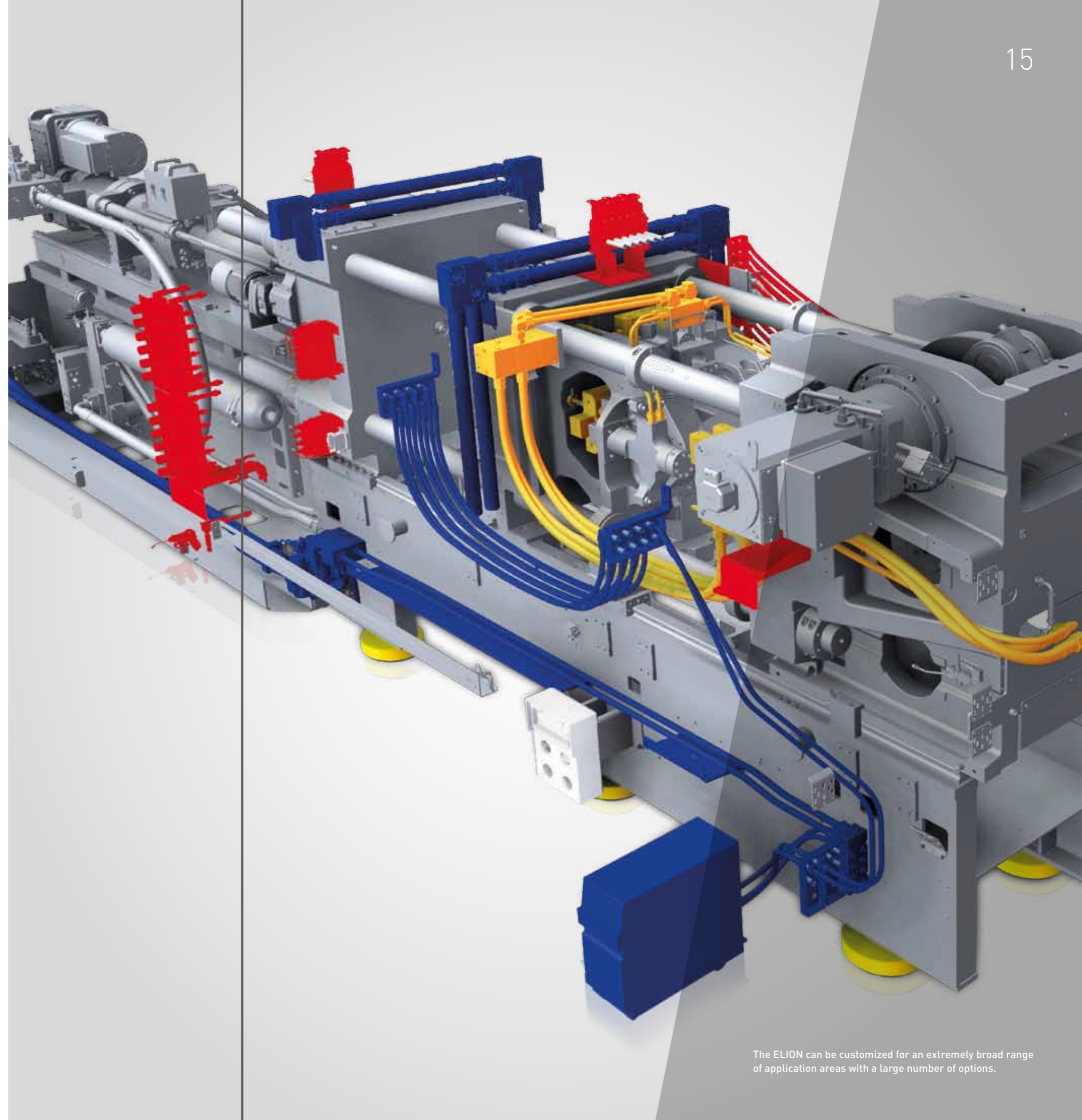



## aXos Control Innovative and user-friendly

The aXos control enables users to create the production processes they require in a way that is both customizable and cost-effective.



The aXos\* operating philosophy brings together the very different requirements of operators from the many areas of application in which injection molding machines are used. Consequently, the operating keyboard offers users a range of facilitating functions, such as shortcut buttons for quick access to desired topics, or the 17-inch TFT flat screen, which serves as a display medium for the entire programming setup.

### Sequence editor

The sequence editor can be used to create a graphical representation of any production process, into which simple commands can then be subsequently incorporated using the corona by moving the cursor. The corona is context-sensitive and offers optional commands and available insertion points for these commands.

### Component manager

The component manager covers all the non-primary axes of a machine (e.g. auxiliary mold controls, blowing controls, conveyor belts, reject gate, etc.), which can be created for individual upgrades and freely configured by the user.

### Operating keyboard

The operating keyboard is equipped with shortcut buttons to provide fast access to topics, as well as having navigation buttons, a trackball and a numeric keypad. The keyboard is ergonomically designed and can be folded down during maintenance.

\*aXos will be available for all clamping unit sizes of the ELION Series in the future

### 17-inch flat screen

Serving as a display medium for the entire programming setup, the flat screen is slightly tilted to optimize screen readability. Users can navigate the TFT flat screen using cursor buttons or the centrally located trackball.

### Operating panel

#### (keyboard for manual operation)

The operating panel offers a whole range of functions to support user operation of the machine during day-to-day work. The combination of screen and membrane keyboard is a development that has been patented by Netstal.

### Your benefits:

- Flexible sequence programming
- All-purpose
- Intuitive operating concept
- Effective safety mechanisms
- Efficient thanks to graphical programming



- 1 Field for process value display
- 2 Field for system message list
- 3 Navigation to topics
- 4 Sequence editor / aXos task pane
- 5 Command parameter field
- 6 User ID
- 7 Global functions
- 8 Activation field
- 9 Status display

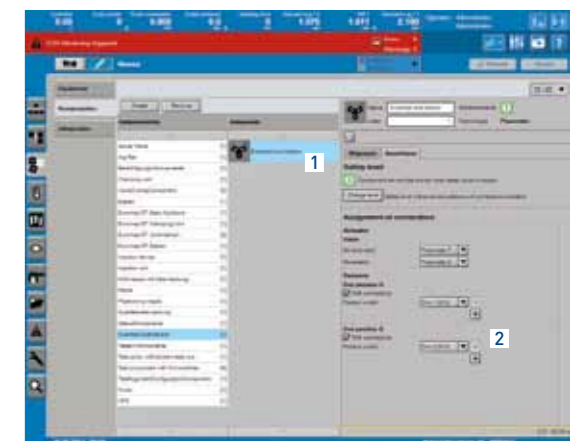

- 1 Created component "Switched core traction"
- 2 Assignment of (sensors/actuators)

## Netstal Life Cycle Services – A Partnership to Last a Machine's Lifetime



Netstal's customer service provides you with optimum support throughout the entire life of your machine. Our solution-oriented services and products such as commissioning support, troubleshooting, spare parts supply and customer training optimize your production efficiency and secure your investment to create a life-long partnership that works to your advantage.

### Start-up phase

- Commissioning
- Training
- Maintenance consultation
- Parts finder

### Optimization phase

- Upgrades
- Energy optimization
- Production optimization
- Remote Support

### Utilization phase

- 24-hour spare parts hotline
- Inspection
- Calibration
- Hotline – technical customer service

### End phase

- Relocation of production
- Overhaul
- Rental and lease machines
- Trade of used machines

## Netstal A strong brand in a unique global group

### Premium high-performance and high-precision Injection Molding Machinery and system solutions

Netstal is an international provider of premium high-performance and high-precision Injection Molding Machinery and system solutions. Our customers are always impressed by the innovations and services that we provide, as well as by our efficient and performance-driven technological approaches for the beverage, packaging and medical technology sectors in particular. Our production systems are all characterized by the same attributes: speed, precision, reli-

ability, user friendliness and operational efficiency. We are constantly refining our technological standard of excellence and, thanks to our innovative technologies, we are able to offer high-performance production systems to our customers.

### There for you around the world

With eight subsidiaries and around 30 distributors, our global presence guarantees optimum customer proximity. This means that we are able to address your individual needs as quickly as possible and provide you with a comprehensive and customer-oriented service.

### Individualized service

While our customer service supports you with a range of solution-oriented services and products, it also excels as a provider of "classic" services thanks to its high reliability and quality standards. Be it commissioning, troubleshooting or customer training – make the most of our first-class services.

You can find additional information about Netstal at: [www.netstal.com](http://www.netstal.com)

## KraussMaffei Group Comprehensive expertise

### Unique selling proposition Technology<sup>3</sup>

The KraussMaffei Group is the only provider in the world to possess the essential machine technologies for plastics and rubber processing with its KraussMaffei, KraussMaffei Berstorff and Netstal brands: Injection Molding Machinery, Automation, Reaction Process Machinery and Extrusion Technology.

The group is represented internationally with more than 30 subsidiaries and over ten production plants as well as about 570 commercial and service partners. This is what makes us your highly skilled and integrated partner. Use our comprehensive and unique expertise in the industry.

You can find additional information at: [www.kraussmaffeigroup.com](http://www.kraussmaffeigroup.com)



The KraussMaffei Group has a global presence. Countries with subsidiaries are marked in light blue. In the white-colored regions, the Group is represented by over 570 sales and service partners.

Fast.  
Precise.  
Efficient.

## Machines from the ELION Series

Fast, precise, reliable, user-friendly and efficient in operation. The ELION has all the typical Netstal features. In addition, it offers a large number of innovative detailed solutions that leave no wishes unfulfilled when it comes to modern injection molding machines. With either an all-electric or hybrid design, the ELION is the perfect choice for a broad range of demanding applications. All models from the ELION series are based on the unique clamping unit principle with a central 5-point toggle lever.

The continuous development of our series and the use of innovative technologies mean that we are able to provide our customers with powerful, cost-effective production systems.